

Buggy Steam Resonator

- [.STEP and STLs](#)

.STEP and STLs

The following .STEP and STL files are from Memo WFC 423-DA. The .STEP files have been provided for CNC machining. STLs are for 3D printing. Discrepancies were found with Stan's original dimensions. A 3D printed model was built and the .STEP files were modified to reflect the corrected dimensions.

NOTE FROM ETHAN CROWDER: I've used PCBWay's CNC machining services without any issue. Our group is not affiliated with them, nor do we receive any sponsorships for mentioning them. I've provided these for free so anyone in the world with the resources can have the electrodes made. Gerber files for the PCB are provided as a link below.

There are certain individuals that have a habit of taking other's work and claiming it as their own. While I won't name them here, please understand that the .STEP and STL files will probably show up on other websites, possibly for purchasing. The files provided here are FREE OF CHARGE. The original Memo WFC 423 DA diagrams are included for clarity.

PCB Gerber Link: [Steam Resonator PCB Gerbers](#)

STL FILES

Steam Resonator S/R Mount Base: [SRMountBlock-SteamResonator_12-31-25.stl](#)

Steam Resonator Insulation Block: [InsulationBlock-SteamResonator_12-31-25.stl](#)

Steam Resonator End Cap: [EndCap-SteamResonator_12-31-25.stl](#)

Steam Resonator Terminal Cap: [TerminalCap-SteamResonator_12-31-25.stl](#)

Steam Resonator Delrin Nut: [DelrinNut-SteamResonator_12-31-25.stl](#)

.STEP FILES

Steam Resonator Inner Excitor Rod: [InnerExcitorRod-SteamResonator_12-31-25.step](#)

Steam Resonator Outer Excitor Tube: [OuterExcitorTube-SteamResonator_12-31-25.step](#)

Steam Resonator S/R Mount Base: [SRMountBlock-SteamResonator_12-31-25.step](#)

Steam Resonator Terminal Cap: [TerminalCap-SteamResonator_12-31-25.step](#)

Steam Resonator End Cap: [EndCap-SteamResonator_12-31-25.step](#)

Steam Resonator Mount Pin: [MountPin-SteamResonator_12-31-25.step](#)

Steam Resonator Stem Plate: [StemPlate-SteamResonator_12-31-25.step](#)

Steam Resonator Insulation Block: [InsulationBlock-SteamResonator_12-31-25.step](#)

Steam Resonator Delrin Nut: [DelrinNut-SteamResonator_12-31-25.step](#)

WFC 423-DA DIAGRAMS:

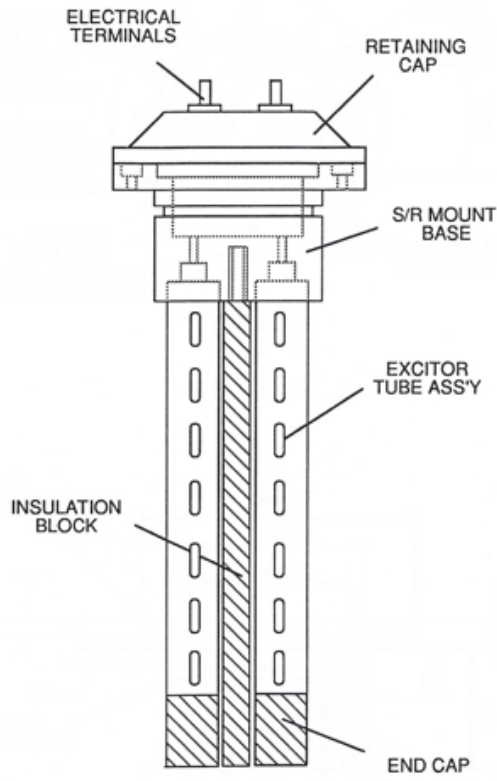

FIGURE 13-1: STEAM RESONATOR ASS'Y

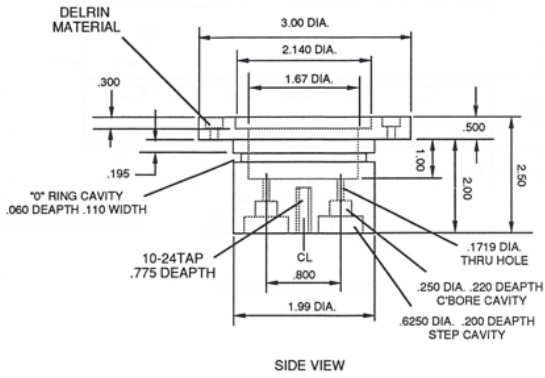
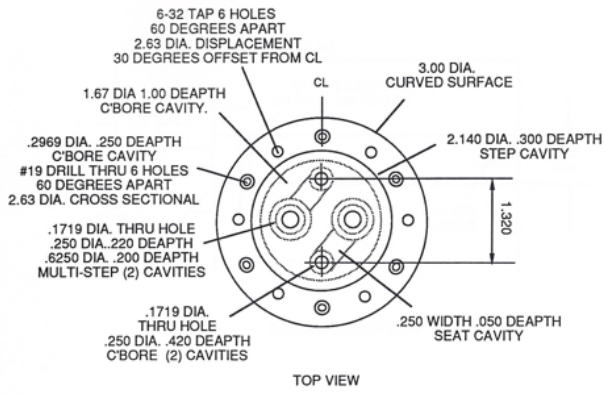
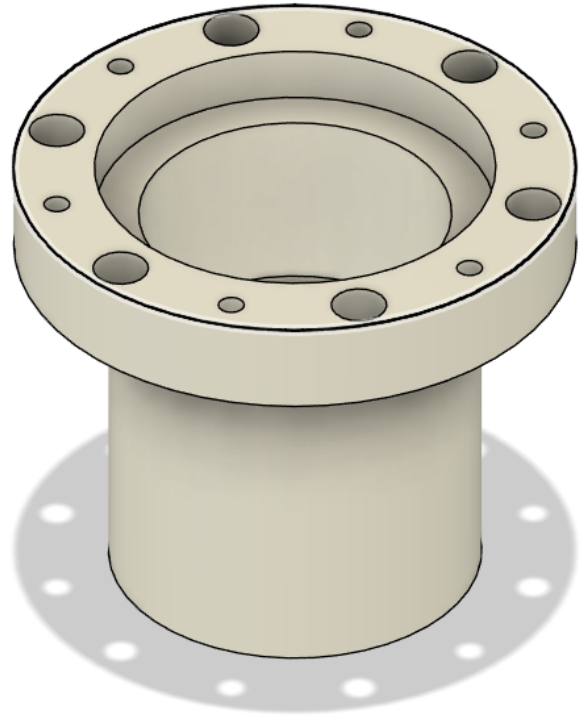

FIGURE 13-2: S/R MOUNT BASE



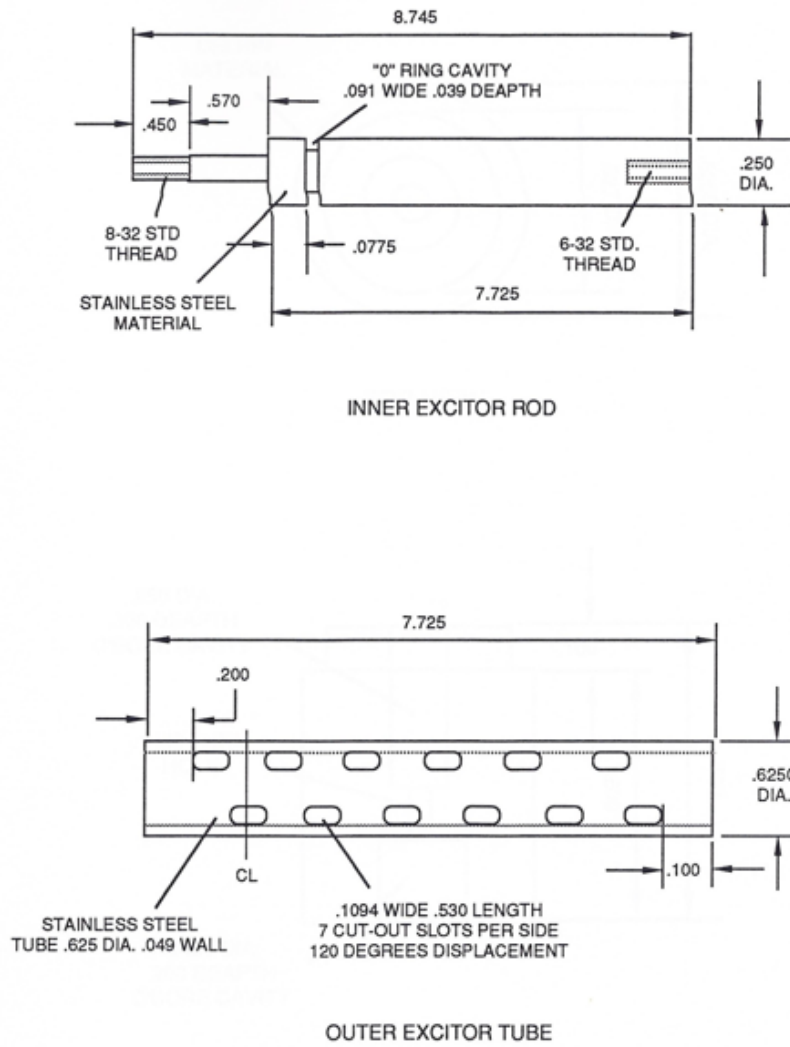

FIGURE 13-3: EXCITOR TUBE ASS'Y

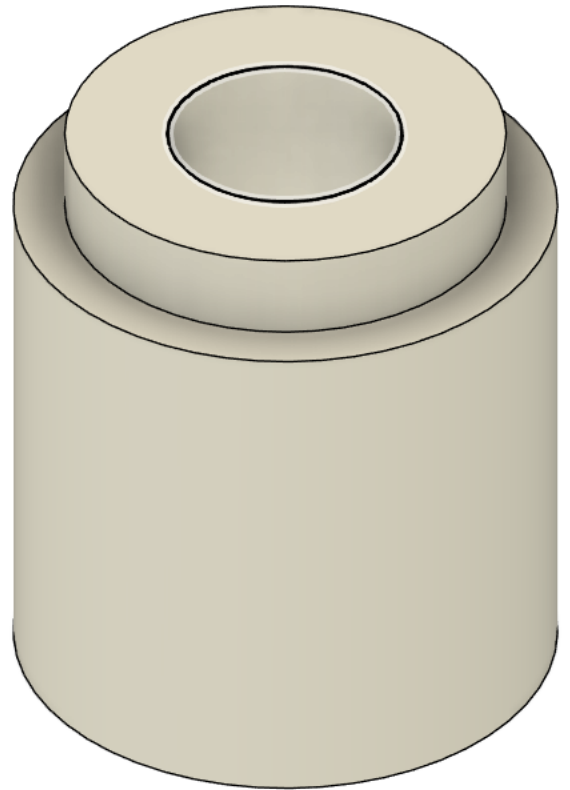
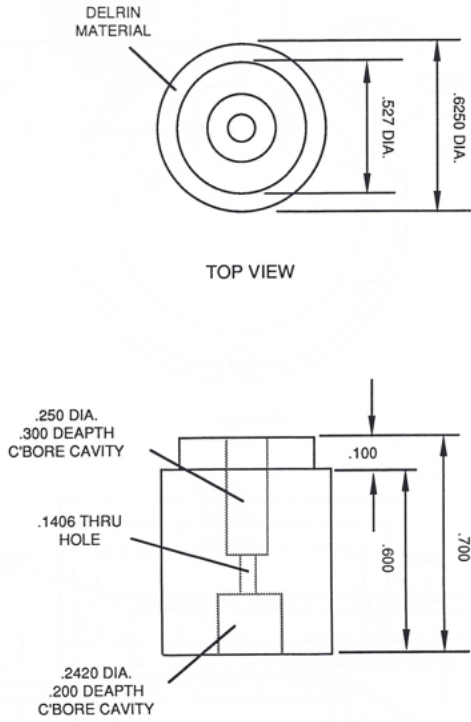

FIGURE 13-4: END CAP

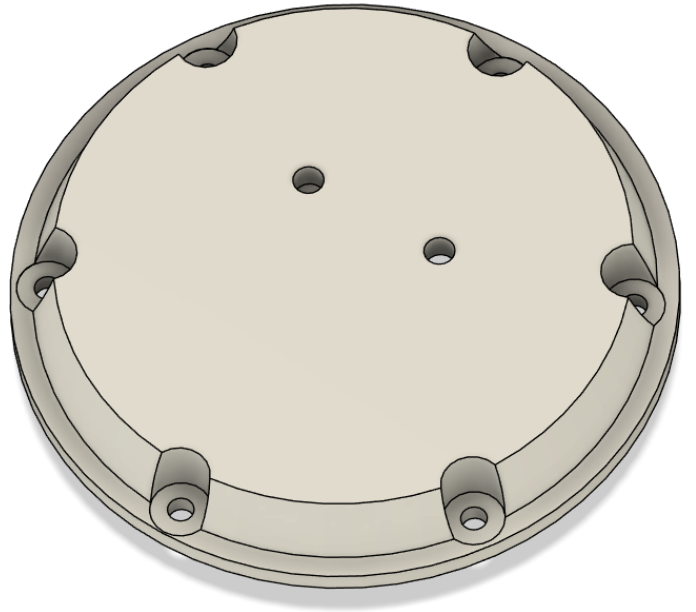
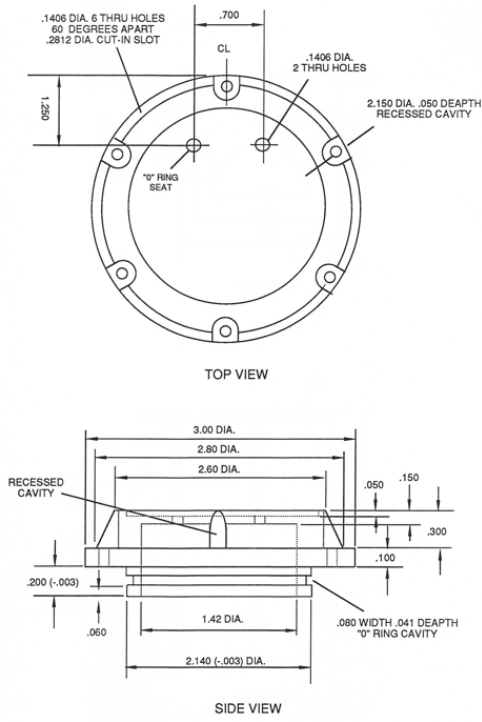

FIGURE 13-5: TERMINAL CAP

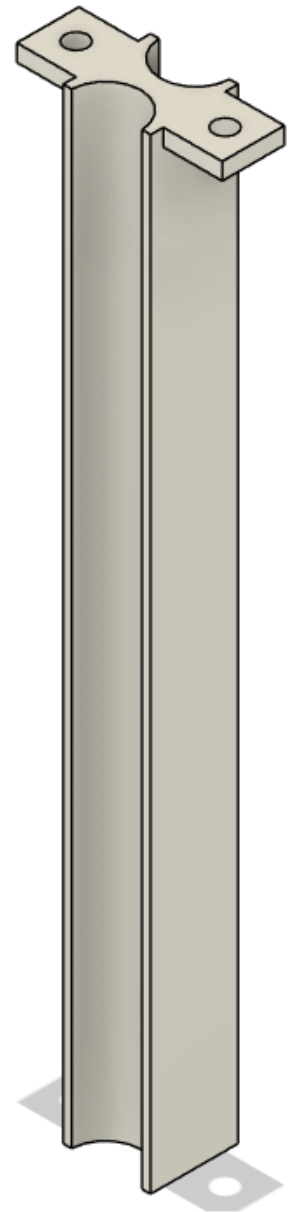
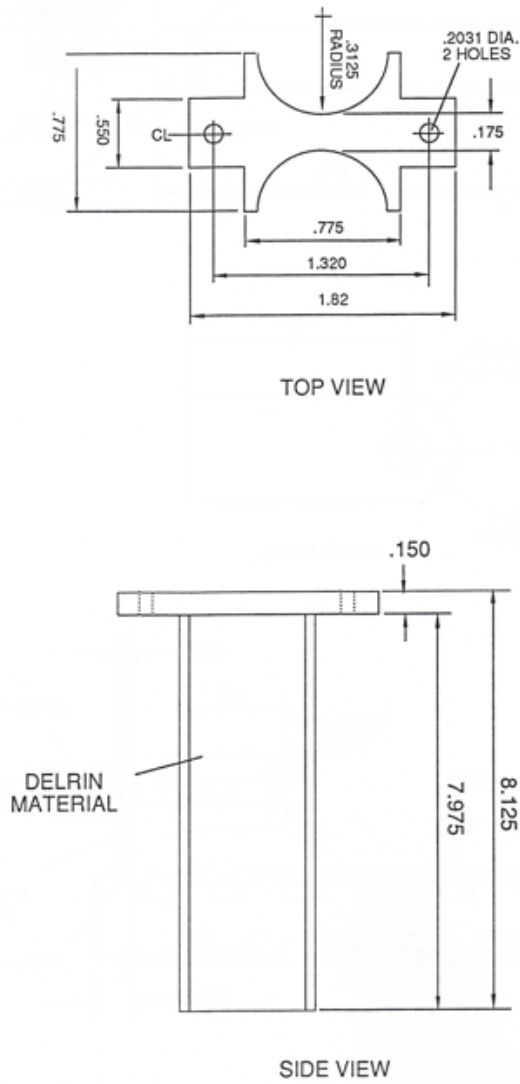
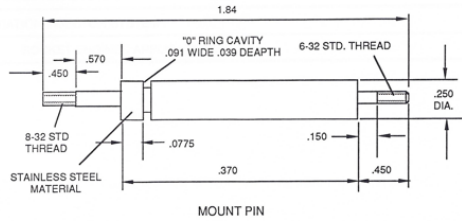
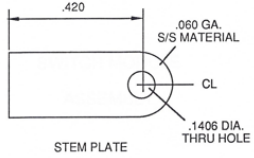

FIGURE 13-6: INSULATION BLOCK



MOUNT PIN



STEM PLATE

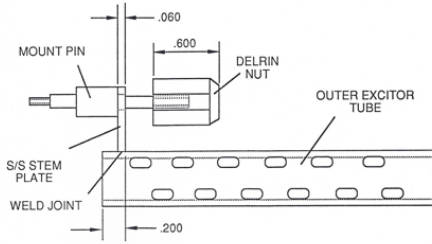

FIGURE 13-7: TERMINAL POST ASSY

