

Custom Power Supplies

- [Basic Flyback Converter Circuit](#)
- [Basic Forward Converter Mode](#)
- [LM317 as a Variable Power Supply: 0-35V Adjustable Voltage](#)
- [9XD: The 7805/7812 Voltage Regulator Supply](#)

Basic Flyback Converter Circuit

VIC comparison to the SMPS Flyback Converter

The SMPS Flyback Converter	The VIC
article-2018january-design-aswitch-mode-fig1 (1).webp	269976205_4901834949839320_7108576882690660460_n (

Suggested VIC circuit operation ON vs OFF states.

[264198905_4779692662053550_2422591929249031513_n.jpg](#)

Basic Forward Converter Mode

The VIC compared to a basic Forward Converter

download (4).png	269976205_4901834949839320_7108576882690660460_n
----------------------------------	------------------------------------------------------------------

LM317 as a Variable Power Supply: 0-35V Adjustable Voltage

7805 and 7812 Voltage Regulators: Building 5V and 12V Power Supplies

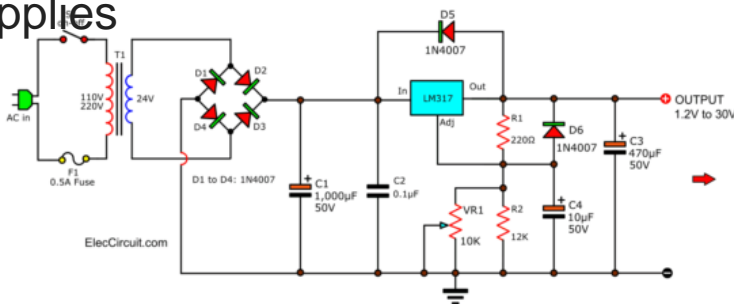

LM317 Power supply circuit 1.2 to 30V 1A

The **7805** and **7812** are popular and

reliable voltage regulators used to create stable 5V and 12V outputs, making them ideal for low-power electronics and microcontroller circuits. These voltage regulators are widely used because of their simplicity, efficiency, and capability to provide steady output voltages regardless of input variations. In this article, we will explore how to set up both 7805 and 7812 voltage regulator circuits, as illustrated in Stanley Meyer's schematic, to create regulated 5V and 12V power supplies.

How the 7805 and 7812 Voltage Regulators Work

The **7805** and **7812** are three-terminal voltage regulators that provide fixed output voltages of **5V** and **12V** respectively. They are capable of handling input voltages between **7V and 35V** for the **7805** and **14V and 35V** for the **7812**. These regulators output stable voltages suitable for powering most small electronic circuits. The three pins on both regulators are:

- **Input (Vin):** The input voltage, which needs to be greater than the desired output by at least 2V.
- **Ground (GND):** The common ground for both the input and output.
- **Output (Vout):** The regulated output voltage, fixed at 5V for the 7805 or 12V for the 7812.

Both regulators have internal current limiting and thermal shutdown features, which make them reliable options for most low-power electronics projects.

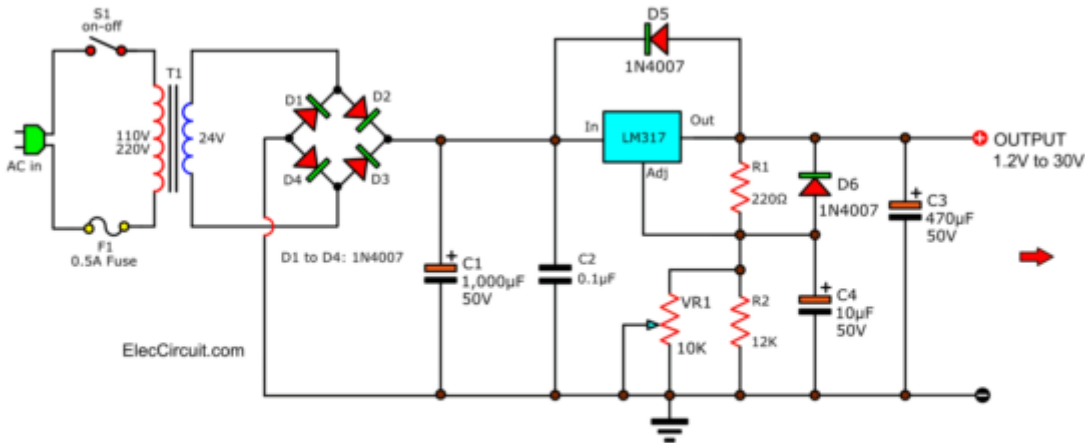

LM317 Power supply circuit 1.2 to 30V 1A

Setting Up the 7805 and 7812 as Power Supplies

To create reliable 5V and 12V power supplies, you'll need a few components in addition to the **7805** or **7812** voltage regulators:

- **Step-Down Transformer:** A transformer to step down the AC voltage from 110V to around **12V AC** for the 7805 or **15V AC** for the 7812.
- **Bridge Rectifier (B1):** A full-wave bridge rectifier to convert the AC voltage to DC.
- **Filter Capacitors (C1, C2, C3):** These capacitors are used to smooth out the DC voltage after rectification, typically **1000µF, 35V** capacitors.
- **Input Capacitor (C4, 0.1µF):** This capacitor helps stabilize the input voltage to the regulator.
- **Heat Sink (optional):** To prevent the regulator from overheating, especially if the current draw is significant.

Here is how to wire the 7805 or 7812 as a regulated power supply:

1. **AC to DC Conversion:** Start by connecting the **step-down transformer (T3)** to the **110V AC input** to step down the voltage to **12V AC** (for 7805) or **15V AC** (for 7812). The AC output is then fed to the **full-wave bridge rectifier (B1)**, which converts the AC into DC voltage.
2. **Filtering the DC Voltage:** Use the **filter capacitors (C1, C2, C3)**, each rated at **1000 μ F, 35V**, to smooth out the DC voltage. These capacitors help reduce the ripple and ensure a steady DC voltage is provided to the voltage regulator.
3. **Voltage Regulation:** Connect the output from the filter capacitors to the **Vin** pin of the **7805** or **7812**. Add an **input capacitor (C4, 0.1 μ F)** between the **Vin** pin and ground to stabilize the input. The **GND** pin is connected to the common ground, and the **Vout** pin provides the regulated **5V** (for 7805) or **12V** (for 7812) output.
4. **Output Filtering:** To ensure a stable output, you can add a small **capacitor** (typically **0.1 μ F**) between the **Vout** pin and ground. This helps filter out any high-frequency noise.

Practical Considerations

- **Heat Dissipation:** When there is a large difference between the input voltage and the regulated output (e.g., 15V input to 12V output), the regulator will dissipate excess energy as heat. To prevent overheating, attach a **heat sink** to the regulator.
- **Current Capability:** Both the 7805 and 7812 can supply up to **1A** of current, but this depends on the input voltage and the ability to dissipate heat. If the current requirement is higher, consider using a switching regulator or adding a more efficient cooling solution.
- **Input Voltage:** Ensure that the input voltage is at least **2V** higher than the desired output. For the **5V** output, the input should be at least **7V**, and for the **12V** output, the input should be at least **14V** to maintain proper regulation.

Using the 7805 or 7812 in a Project Box

To create practical 5V or 12V power supplies, you can mount the **7805** or **7812** circuit in a project box. Add an external **on/off switch**, input and output terminals, and consider adding a **fuse** on the input for safety. This can provide a versatile power source for your electronics projects.

LM317 as a Variable Power Supply

The **LM317** is another popular voltage regulator that can be used to create a variable power supply with an adjustable output ranging from **1.25V to 35V**. This makes it suitable for projects requiring a flexible voltage source.

To wire the **LM317** as a variable power supply, follow these steps:

- **Input Voltage:** Connect the input voltage source (e.g., **12V-40V DC**) to the **Vin** pin of the **LM317**. A **0.1 μ F capacitor** can be added between the input and ground to stabilize the input voltage.

- **Output Voltage:** Connect the **Vout** pin to the positive terminal of your load. Add a **1 μ F capacitor** between the output and ground to improve stability and reduce ripple.
- **Adjust Pin and Voltage Divider:** To control the output voltage, connect a **240 Ω resistor** between the **Vout** and **Adjust** pins. Then, connect a **potentiometer** (typically **5k Ω or 10k Ω**) between the **Adjust** pin and ground. The potentiometer acts as an adjustable resistor that allows you to vary the voltage.

The output voltage (βV_{out}) can be calculated using the following formula:

$$V_{out} = 1.25V \times (1 + R2 / R1) + I_{adj} \times R2$$

Where:

- **R1** is the fixed resistor (typically **240 Ω**).
- **R2** is the resistance of the potentiometer, which varies as you adjust it.
- **I_{adj}** is a small adjustment current (typically ignored for most practical purposes).

Conclusion

The **7805**, **7812**, and **LM317** voltage regulators are easy and reliable solutions for creating regulated power supplies. Whether you need a fixed **5V or 12V** output or a variable output using the **LM317**, these components offer simple setups suitable for a wide range of electronic applications. The addition of heat sinks and careful consideration of input voltages ensure that the regulators operate effectively without overheating. These power supply designs are versatile and can be used to power anything from microcontrollers to sensors, providing stable sources for your DIY electronics projects.

9XD: The 7805/7812 Voltage Regulator Supply

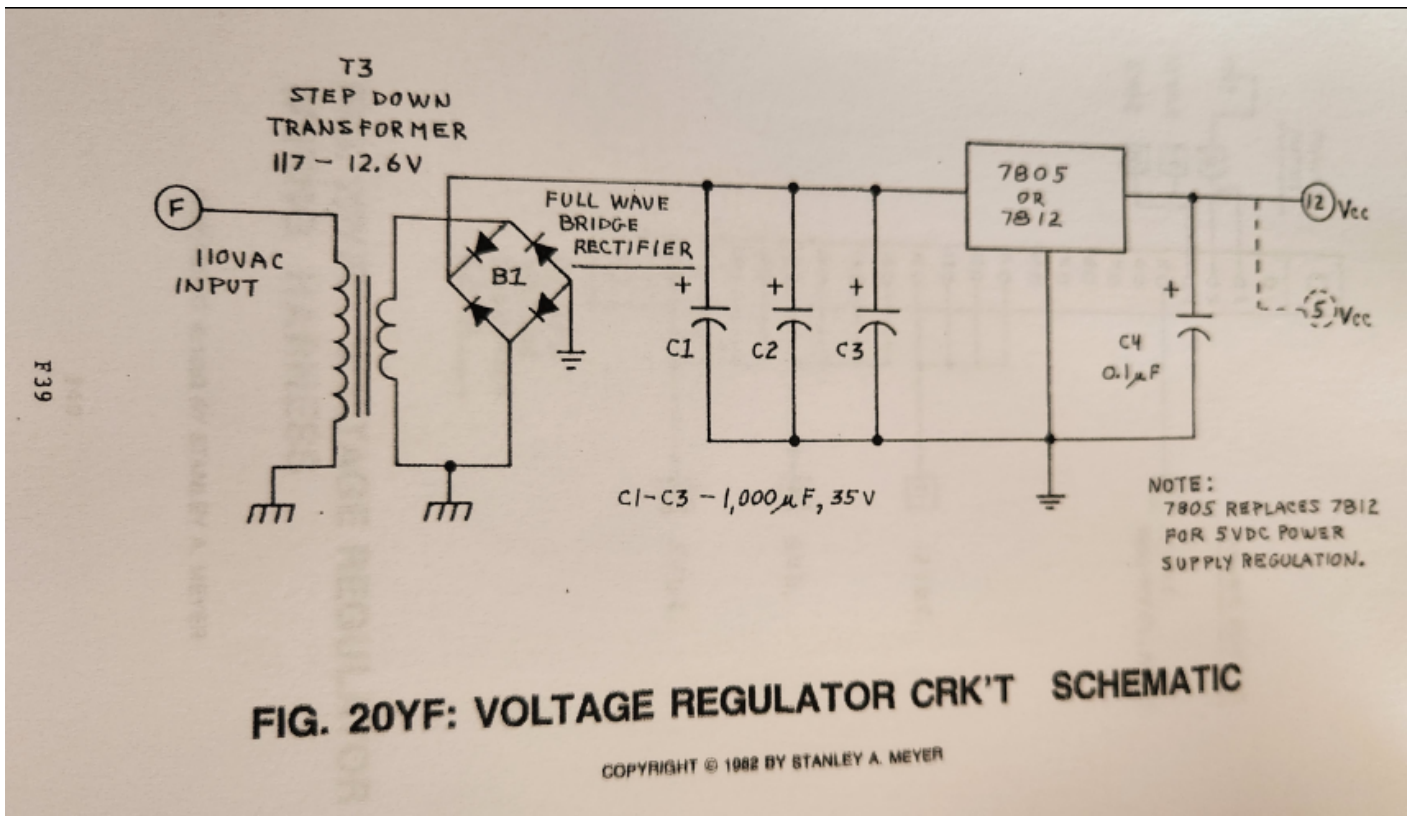

The **7805** and **7812** are popular and reliable voltage regulators used to create stable 5V and 12V outputs, making them ideal for low-power electronics and microcontroller circuits. These voltage regulators are widely used because of their simplicity, efficiency, and capability to provide steady output voltages regardless of input variations. In this article, we will explore how to set up both 7805 and 7812 voltage regulator circuits, as illustrated in Stanley Meyer's schematic, to create regulated 5V and 12V power supplies.

How the 7805 and 7812 Voltage Regulators Work

The **7805** and **7812** are three-terminal voltage regulators that provide fixed output voltages of **5V** and **12V** respectively. They are capable of handling input voltages between **7V and 35V** for the **7805** and **14V and 35V** for the **7812**. These regulators output stable voltages suitable for powering most small electronic circuits. The three pins on both regulators are:

- **Input (Vin):** The input voltage, which needs to be greater than the desired output by at least 2V.
- **Ground (GND):** The common ground for both the input and output.
- **Output (Vout):** The regulated output voltage, fixed at 5V for the 7805 or 12V for the 7812.

Both regulators have internal current limiting and thermal shutdown features, which make them reliable options for most low-power electronics projects.

Setting Up the 7805 and 7812 as Power Supplies

To create reliable 5V and 12V power supplies, you'll need a few components in addition to the **7805** or **7812** voltage regulators:

- **Step-Down Transformer:** A transformer to step down the AC voltage from 110V to around **12V AC** for the 7805 or **15V AC** for the 7812.
- **Bridge Rectifier (B1):** A full-wave bridge rectifier to convert the AC voltage to DC.
- **Filter Capacitors (C1, C2, C3):** These capacitors are used to smooth out the DC voltage after rectification, typically **1000 μ F, 35V** capacitors.
- **Input Capacitor (C4, 0.1 μ F):** This capacitor helps stabilize the input voltage to the regulator.
- **Heat Sink** (optional): To prevent the regulator from overheating, especially if the current draw is significant.

Here is how to wire the 7805 or 7812 as a regulated power supply:

1. **AC to DC Conversion:** Start by connecting the **step-down transformer (T3)** to the **110V AC input** to step down the voltage to **12V AC** (for 7805) or **15V AC** (for 7812). The AC output is then fed to the **full-wave bridge rectifier (B1)**, which converts the AC into DC voltage.
2. **Filtering the DC Voltage:** Use the **filter capacitors (C1, C2, C3)**, each rated at **1000 μ F, 35V**, to smooth out the DC voltage. These capacitors help reduce the ripple and ensure a steady DC voltage is provided to the voltage regulator.
3. **Voltage Regulation:** Connect the output from the filter capacitors to the **Vin** pin of the **7805** or **7812**. Add an **input capacitor (C4, 0.1 μ F)** between the **Vin** pin and ground to stabilize the input. The **GND** pin is connected to the common ground, and the **Vout** pin provides the regulated **5V** (for 7805) or **12V** (for 7812) output.
4. **Output Filtering:** To ensure a stable output, you can add a small **capacitor** (typically **0.1 μ F**) between the **Vout** pin and ground. This helps filter out any high-frequency noise.

Practical Considerations

- **Heat Dissipation:** When there is a large difference between the input voltage and the regulated output (e.g., 15V input to 12V output), the regulator will dissipate excess energy as heat. To prevent overheating, attach a **heat sink** to the regulator.
- **Current Capability:** Both the 7805 and 7812 can supply up to **1A** of current, but this depends on the input voltage and the ability to dissipate heat. If the current requirement is higher, consider using a switching regulator or adding a more efficient cooling solution.
- **Input Voltage:** Ensure that the input voltage is at least **2V** higher than the desired output. For the **5V** output, the input should be at least **7V**, and for the **12V** output, the input should be at least **14V** to maintain proper regulation.

Using the 7805 or 7812 in a Project Box

To create practical 5V or 12V power supplies, you can mount the **7805** or **7812** circuit in a project box. Add an external **on/off switch**, input and output terminals, and consider adding a **fuse** on the input for safety. This can provide a versatile power source for your electronics projects.

Conclusion

The **7805** and **7812** voltage regulators are easy and reliable solutions for creating fixed **5V** and **12V** power supplies. By using a step-down transformer, bridge rectifier, filter capacitors, and the **7805** or **7812** itself, you can build regulated power supplies suitable for a wide range of electronic applications. The addition of heat sinks and careful consideration of the input voltage ensures the regulator operates effectively without overheating. These simple power supply designs can be used to power anything from microcontrollers to sensors, providing stable 5V or 12V sources for your DIY electronics projects.