

Water Fuel Injector Illustrations

2-1 Taper WFC Injector Assembly

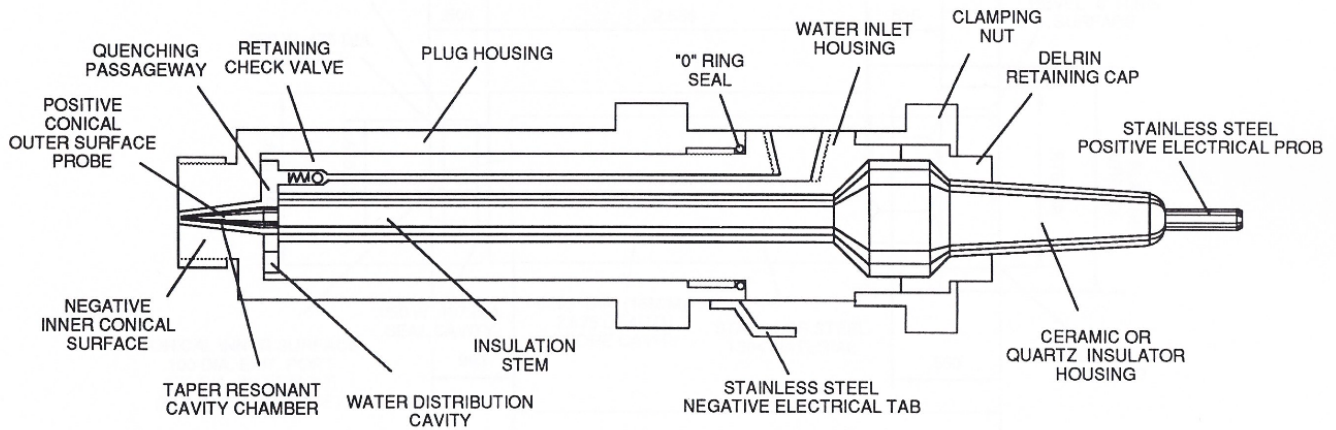

FIGURE 2-1: TAPER WFC INJECTOR ASSEMBLY

2-2 Plug Housing

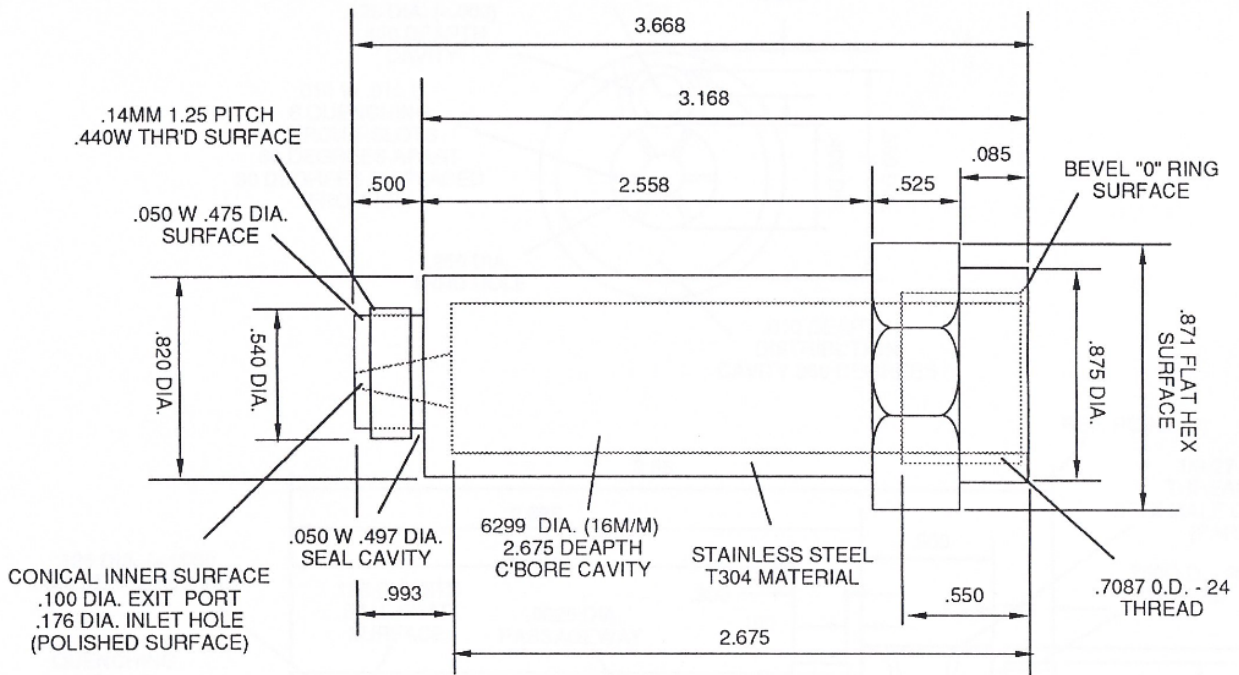

FIGURE 2-2: PLUG HOUSING

2-3 Water Inlet Housing

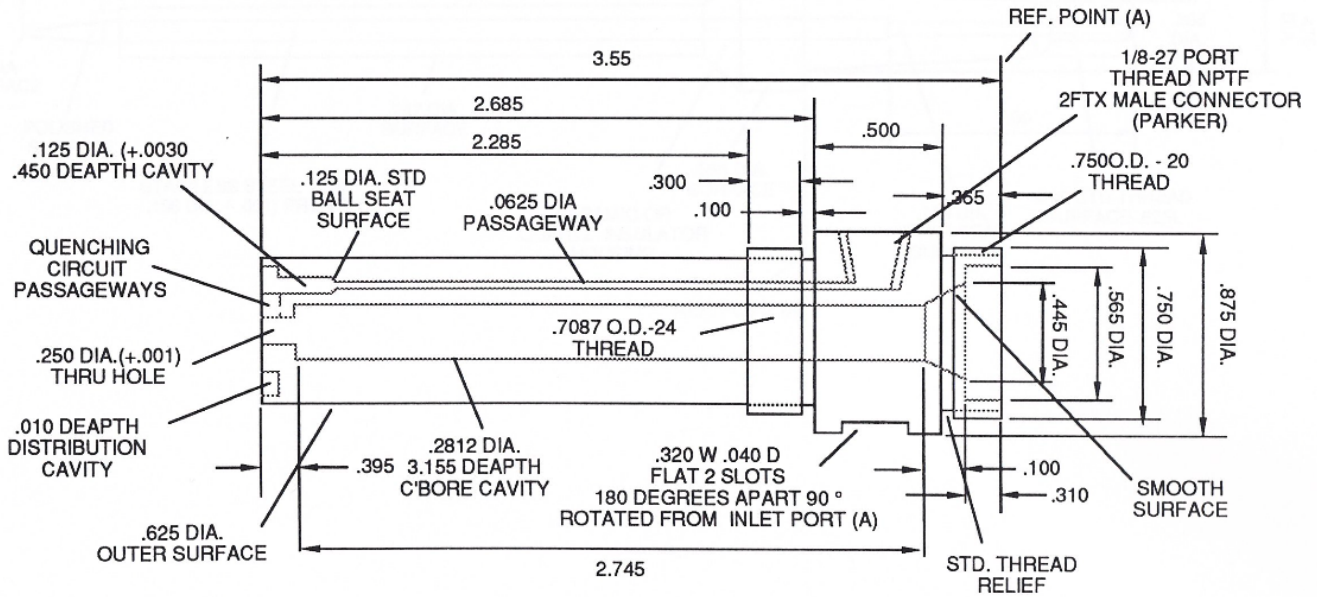
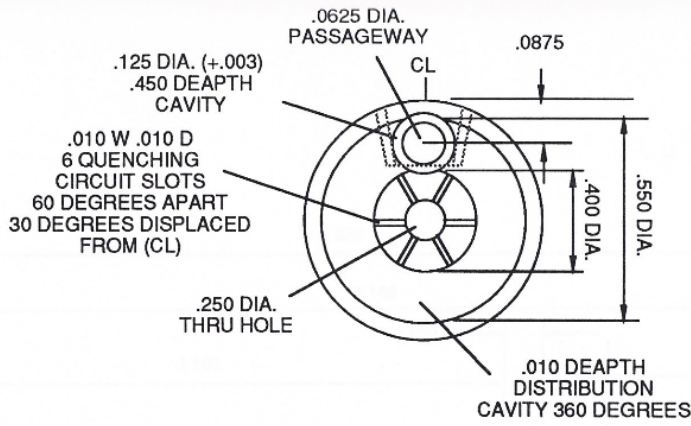

FIGURE 2-3: WATER INLET HOUSING

2-4 Positive Probe Assembly

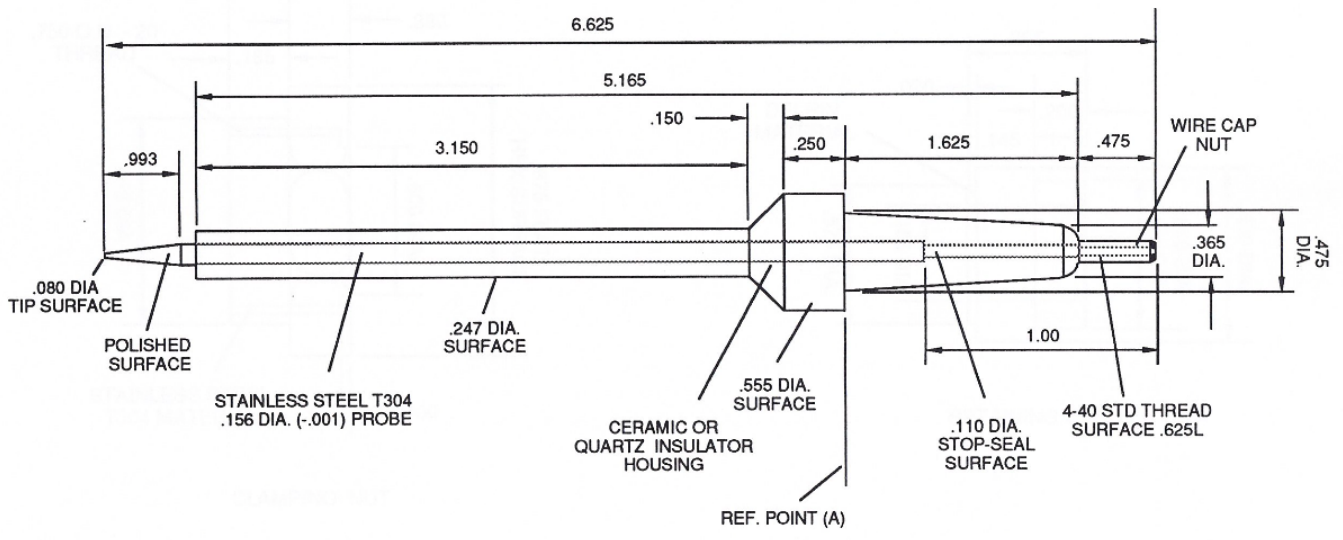

FIGURE 2-4: POSITIVE PROBE ASSEMBLY

2-5 Clamp Nut Assembly

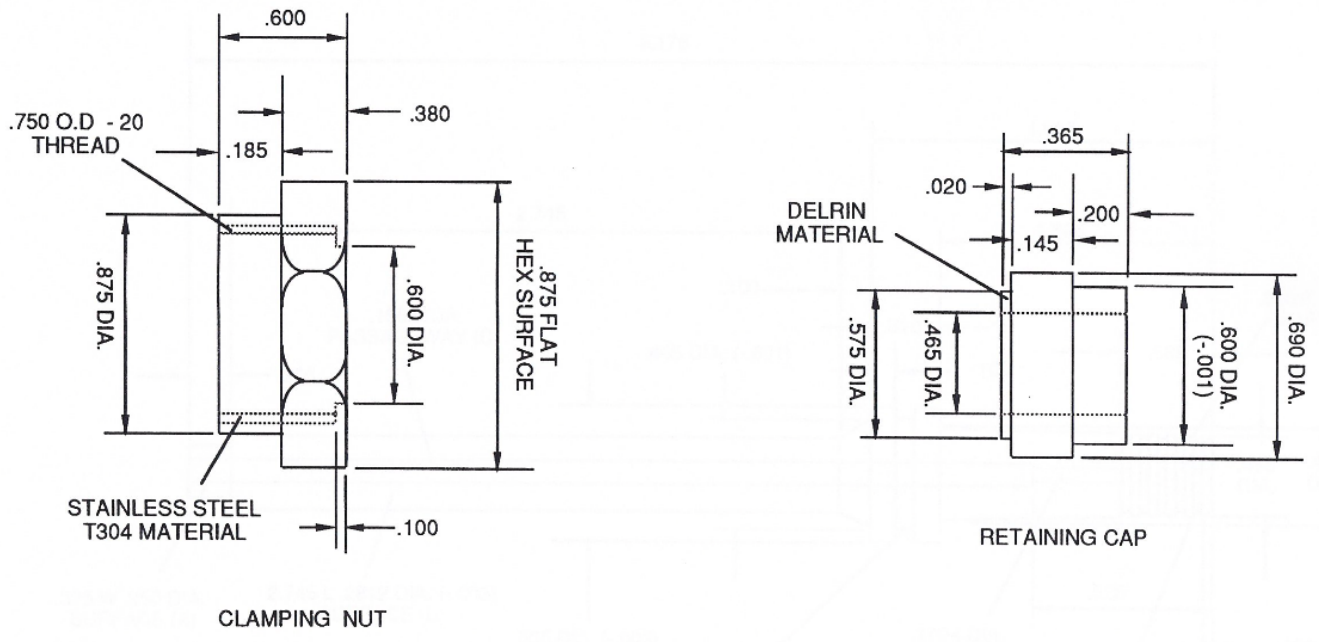

FIGURE 2-5: CLAMP NUT ASSEMBLY

2-6 Ceramic Insert

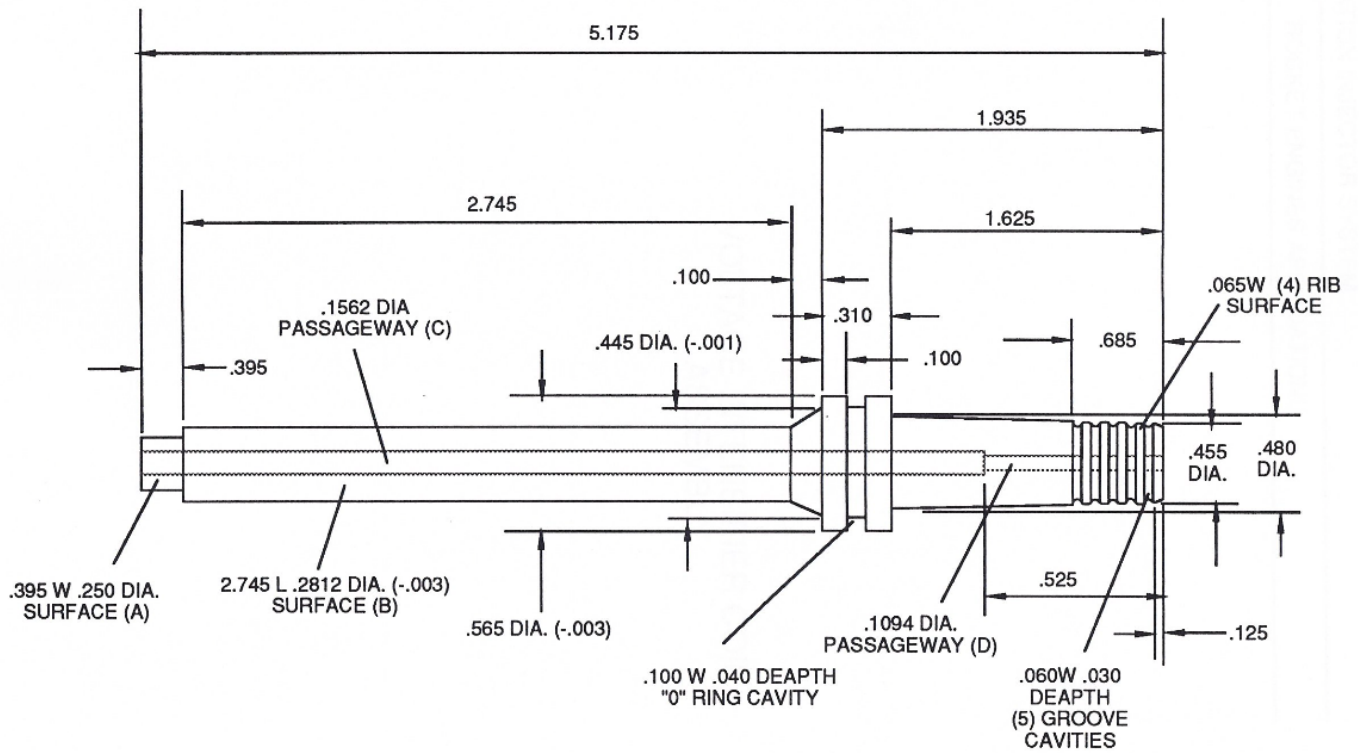

FIGURE 2-6: CERAMIC INSERT

Revision #1

Created 2024-03-24 02:20:14 UTC by Chris Bake

Updated 2024-03-27 16:19:39 UTC by Chris Bake