

Emergency Shut-Down

To "Fine-Tune" or "adjust" the hydrogen burn-rate still further to obtain maximum engine performance, non-combustible gases from the engine exhaust system is meter mixed with the **Fuel-Cell Gases** under control means, as illustrated in Figure 5.

The engine provides the non-combustible gases on demand since **Ambient Air** is used firing the **Gas Combustion Process**.

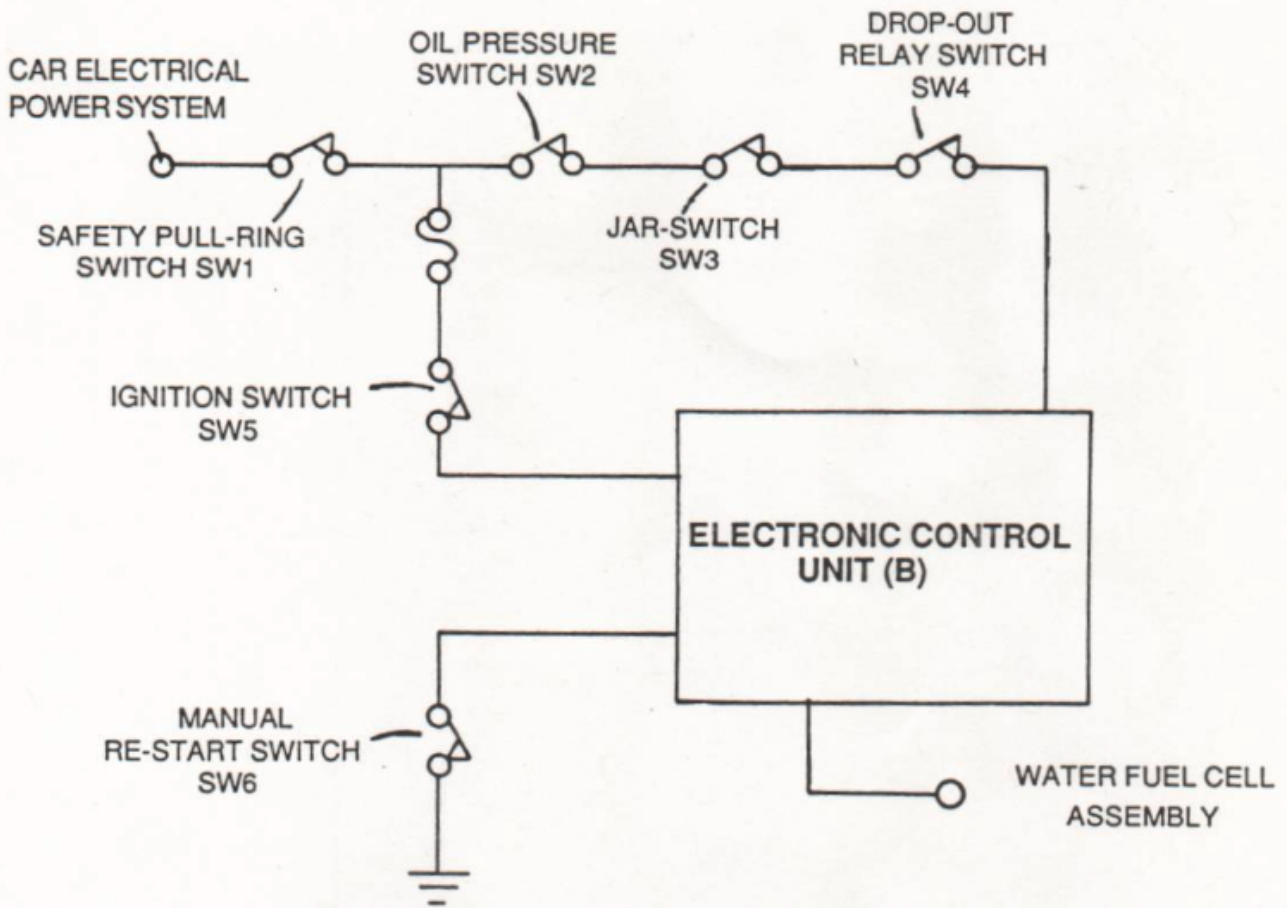

Copyright © 1988 By Stanley A. Meyer

Figure 6: Safety Control Circuit

Revision #4

Created 2024-03-26 04:41:03 UTC by Chris Bake

Updated 2024-03-27 16:19:39 UTC by Chris Bake