

Steam Resonator Assembly

AUTO INJECTOR SYSTEM

AVIATION INJECTOR SYSTEM

ROCKET ENGINES APPLICATIONS

Steam Resonator assembly

Steam Resonator Ass'y

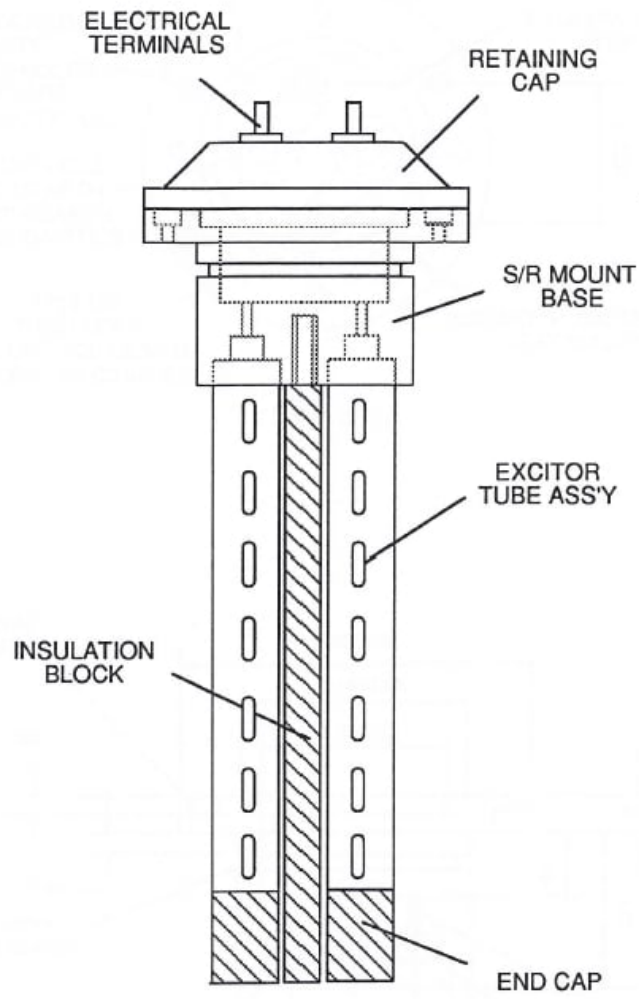

FIGURE 13-1: STEAM RESONATOR ASS'Y

S/R Mount Base

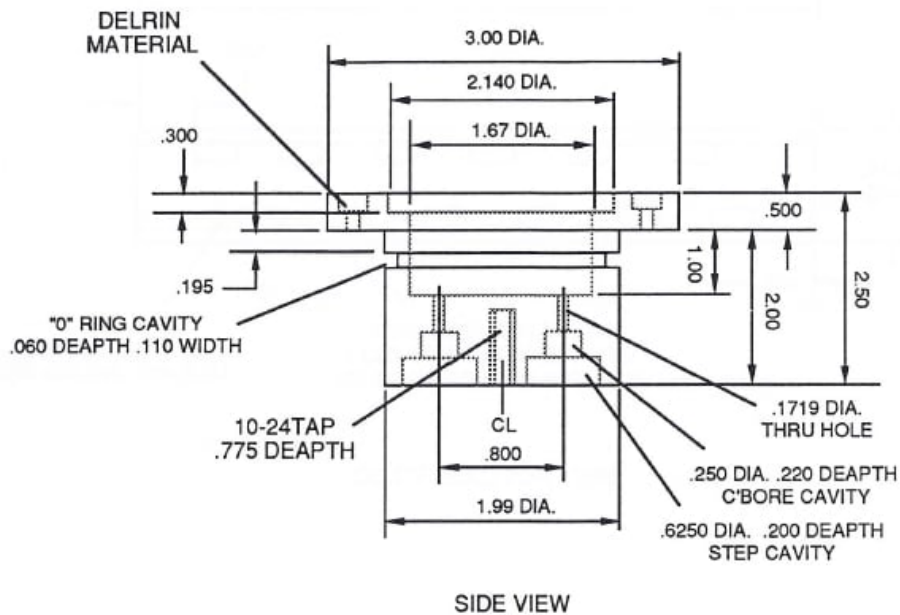
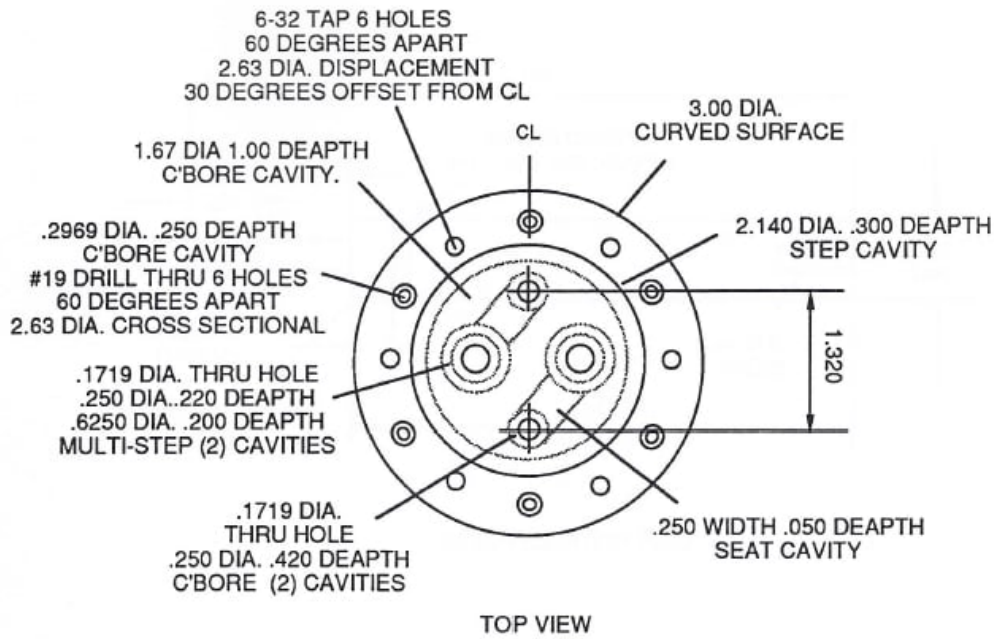
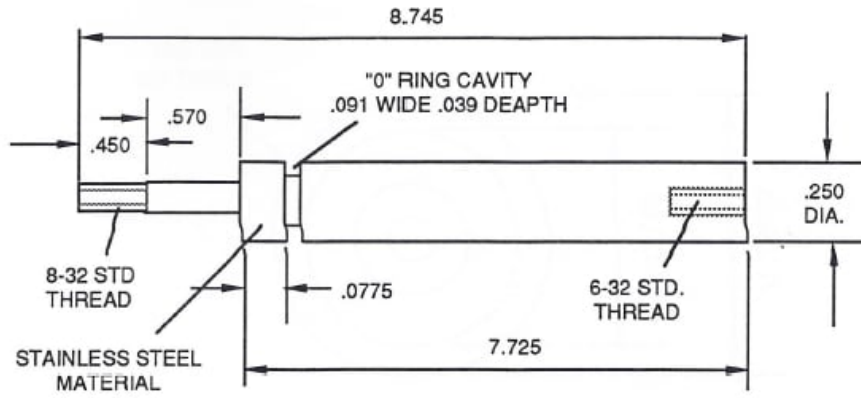
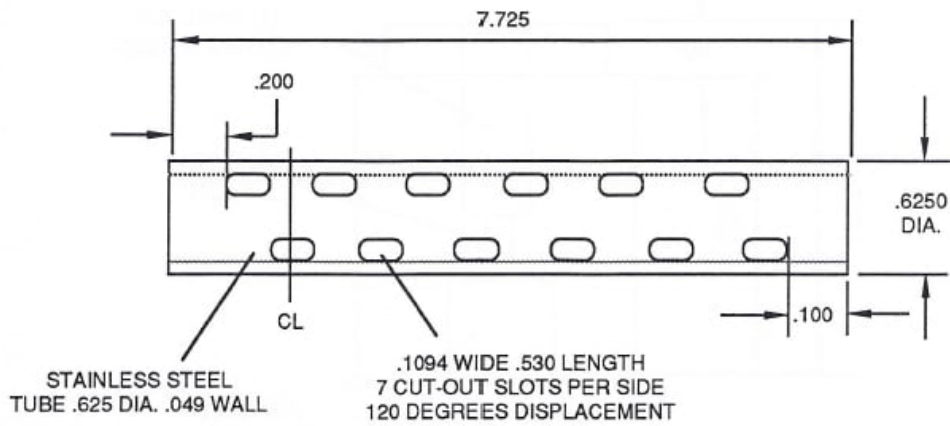

FIGURE 13-2: S/R MOUNT BASE

Excitor Tube Ass'y



INNER EXCITOR ROD



OUTER EXCITOR TUBE

FIGURE 13-3: EXCITOR TUBE ASS'Y

End Cap

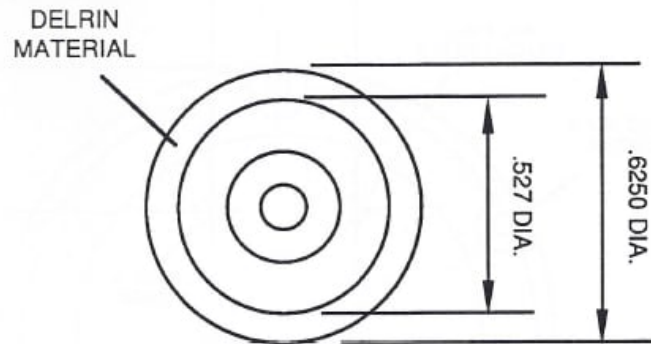

TOP VIEW

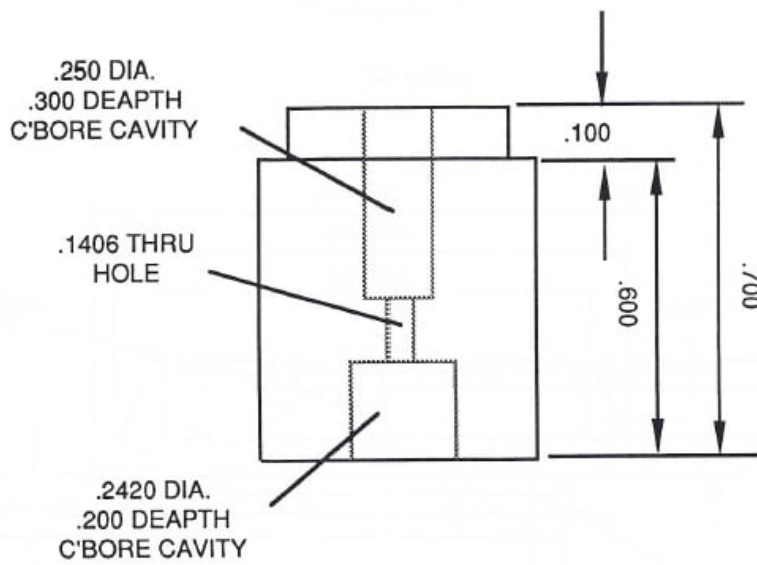

FIGURE 13-4: END CAP

Terminal Cap

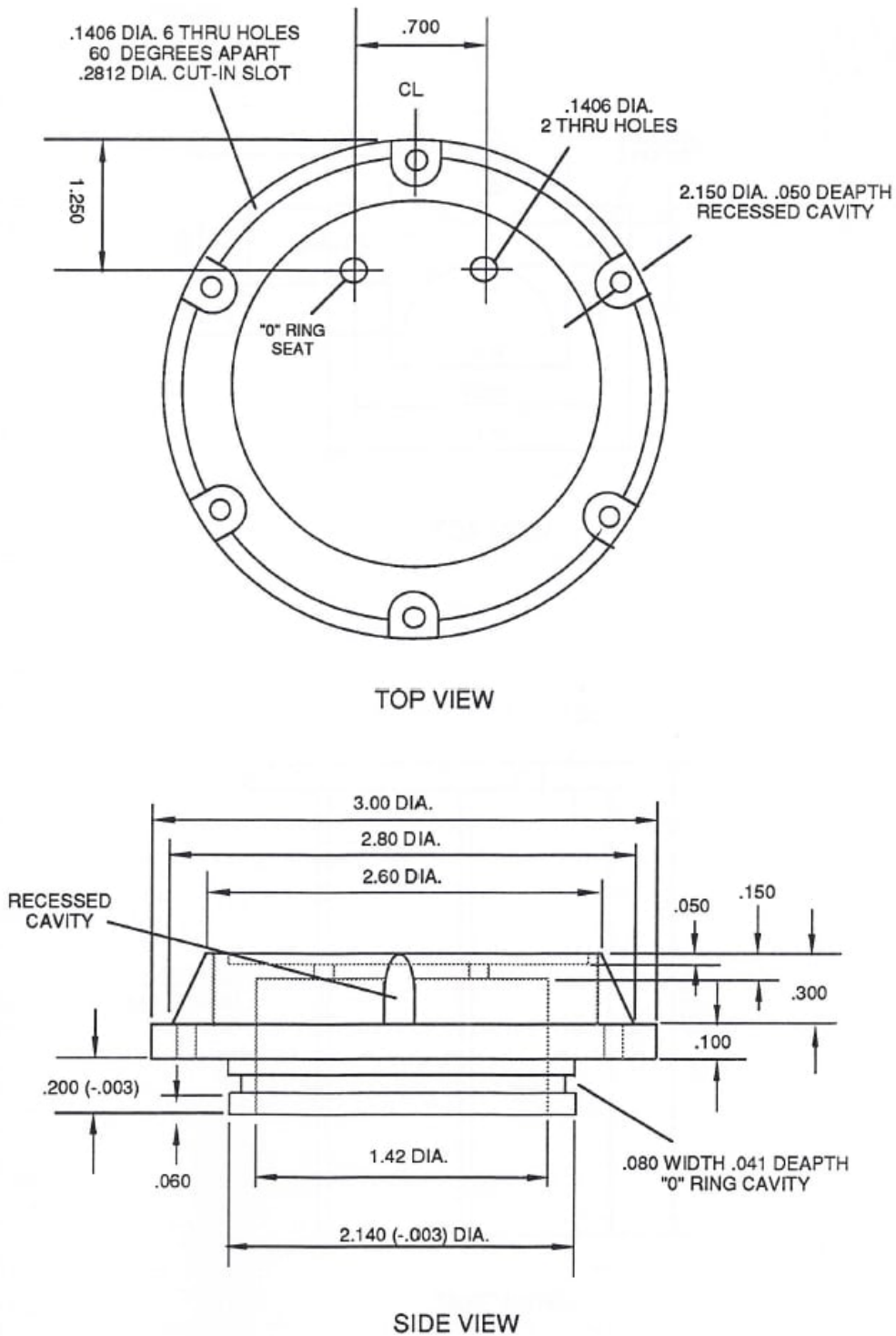
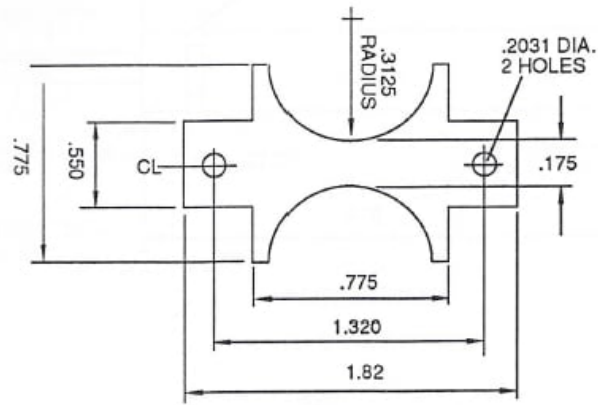
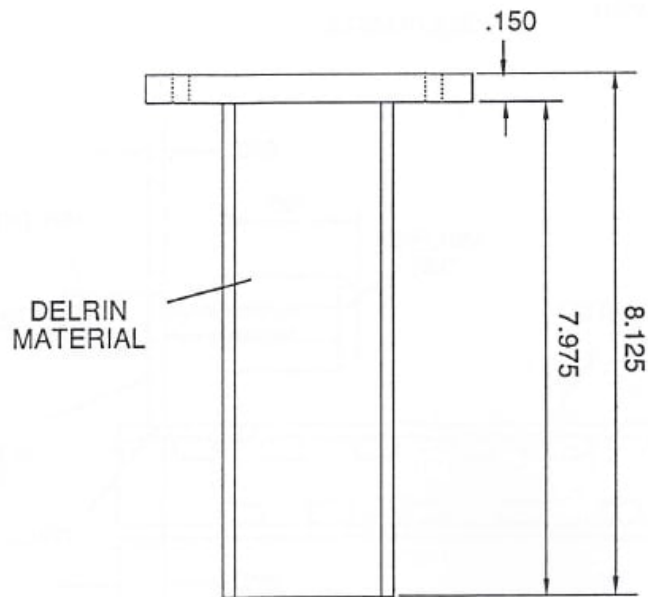

FIGURE 13-5: TERMINAL CAP

Insulation Block



TOP VIEW



SIDE VIEW

FIGURE 13-6: INSULATION BLOCK

Terminal Post Ass'y

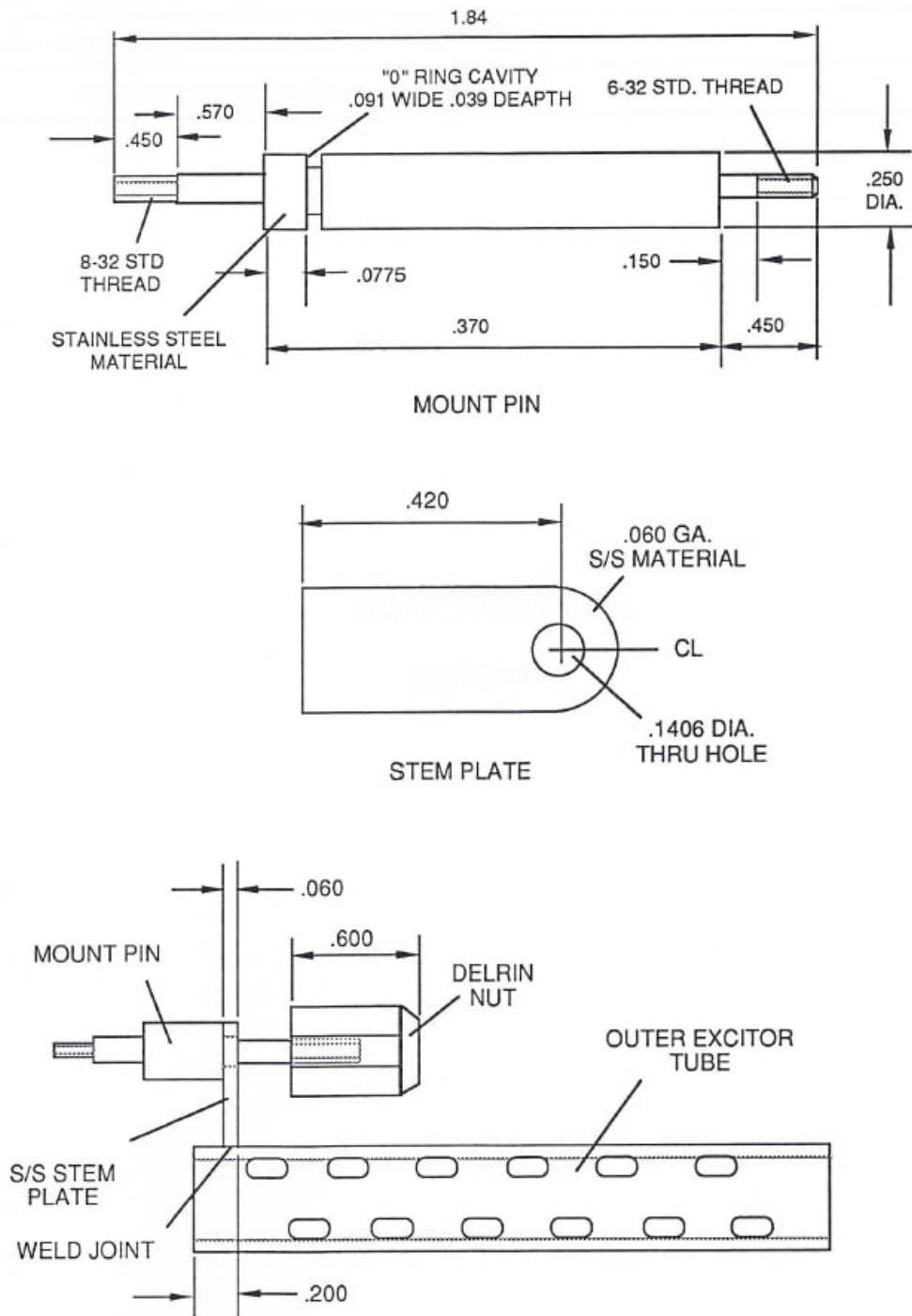

FIGURE 13-7: TERMINAL POST ASS'Y

Revision #1

Created 2024-03-26 04:21:25 UTC by Chris Bake

Updated 2024-04-15 21:51:25 UTC by Chris Bake